

ETSI EN 301 489-9 V1.2.1 (2001-11)

Candidate Harmonized European Standard (Telecommunications series)

**Electromagnetic compatibility
and Radio spectrum Matters (ERM);
ElectroMagnetic Compatibility (EMC)
standard for radio equipment and services;
Part 9: Specific conditions for wireless microphones,
similar Radio Frequency (RF) audio link equipment,
cordless audio and in-ear monitoring devices**



Reference

REN/ERM-EMC-219-9

Keywords

audio, digital, EMC, radio, radio mic, regulation

ETSI

650 Route des Lucioles
F-06921 Sophia Antipolis Cedex - FRANCE

Tel.: +33 4 92 94 42 00 Fax: +33 4 93 65 47 16

Siret N° 348 623 562 00017 - NAF 742 C
Association à but non lucratif enregistrée à la
Sous-Préfecture de Grasse (06) N° 7803/88

Important notice

Individual copies of the present document can be downloaded from:

<http://www.etsi.org>

The present document may be made available in more than one electronic version or in print. In any case of existing or perceived difference in contents between such versions, the reference version is the Portable Document Format (PDF). In case of dispute, the reference shall be the printing on ETSI printers of the PDF version kept on a specific network drive within ETSI Secretariat.

Users of the present document should be aware that the document may be subject to revision or change of status. Information on the current status of this and other ETSI documents is available at

<http://portal.etsi.org/tb/status/status.asp>

If you find errors in the present document, send your comment to:

editor@etsi.fr

Copyright Notification

No part may be reproduced except as authorized by written permission.
The copyright and the foregoing restriction extend to reproduction in all media.

© European Telecommunications Standards Institute 2001.
All rights reserved.

Contents

Intellectual Property Rights	5
Foreword.....	5
1 Scope	7
2 References	7
3 Definitions and abbreviations.....	8
3.1 Definitions	8
3.2 Abbreviations	8
4 Test conditions	9
4.1 General	9
4.2 Arrangements for test signals	9
4.2.1 Arrangements for test signals at the input of transmitters.....	9
4.2.2 Arrangements for test signals at the output of transmitters.....	10
4.2.3 Arrangements for test signals at the input of receivers	10
4.2.4 Arrangements for test signals at the output of receivers	12
4.2.5 Arrangements for testing transmitter and receiver together (as a system).....	12
4.3 Exclusion bands.....	12
4.3.1 Receiver and receivers of transceivers exclusion band.....	12
4.3.2 Transmitter exclusion band.....	12
4.4 Narrow band responses of receivers	13
4.5 Normal test modulation	13
4.5.1 Transmitters	13
4.5.2 Receivers	13
5 Performance assessment.....	13
5.1 General	13
5.2 Equipment which can provide a continuous communications link	13
5.3 Equipment which does not provide a continuous communications link.....	14
5.4 Ancillary equipment.....	14
5.5 Equipment classification	14
6 Performance criteria	14
6.1 General performance criteria.....	15
6.2 Performance criteria for equipment which provides a continuous communication link	15
6.2.1 Performance criteria for Continuous phenomena applied to Transmitters (CT) and Receivers (CR).....	15
6.2.2 Performance criteria for Transient phenomena applied to Transmitters (TT) and Receivers (TR)	16
6.3 Performance criteria for equipment which does not provide a continuous communication link.....	16
6.4 Performance criteria for ancillary equipment tested on a stand alone basis	17
7 Applicability overview	17
7.1 Emission	17
7.1.1 General.....	17
7.1.2 Special conditions.....	17
7.2 Immunity	17
7.2.1 General.....	17
7.2.2 Special conditions.....	18
Annex A (informative): Examples of wireless microphones, cordless audio, in-ear monitoring and similar RF audio link equipment within the scope of the present document	19
A.1 Wireless radio microphone equipment.....	19
A.2 Cordless audio equipment	19
A.3 RF audio link equipment covered within the scope of the present document.....	20

Annex B (normative):	Acoustic stimulation of wireless radio microphones and similar radio communications link equipment, conditions for the test set up and configuration	21
B.1	General	21
B.2	Audio excitation	21
History	22

Intellectual Property Rights

IPRs essential or potentially essential to the present document may have been declared to ETSI. The information pertaining to these essential IPRs, if any, is publicly available for **ETSI members and non-members**, and can be found in ETSI SR 000 314: *"Intellectual Property Rights (IPRs); Essential, or potentially Essential, IPRs notified to ETSI in respect of ETSI standards"*, which is available from the ETSI Secretariat. Latest updates are available on the ETSI Web server (<http://webapp.etsi.org/IPR/home.asp>).

Pursuant to the ETSI IPR Policy, no investigation, including IPR searches, has been carried out by ETSI. No guarantee can be given as to the existence of other IPRs not referenced in ETSI SR 000 314 (or the updates on the ETSI Web server) which are, or may be, or may become, essential to the present document.

Foreword

This Candidate Harmonized European Standard (Telecommunications series) has been produced by ETSI Technical Committee Electromagnetic compatibility and Radio spectrum Matters (ERM).

The present document has been produced by ETSI in response to a mandate from the European Commission issued under Council Directive 98/34/EC [4] (as amended) laying down a procedure for the provision of information in the field of technical standards and regulations.

The present document is intended to become a Harmonized Standard, the reference of which will be published in the Official Journal of the European Communities referencing the Council Directive on the approximation of the laws of the Member States relating to electromagnetic compatibility ("the EMC Directive") (89/336/EEC [3] as amended) and Directive 1999/5/EC of the European Parliament and of the Council of 9 March 1999 on radio equipment and telecommunications terminal equipment and the mutual recognition of their conformity ("the R&TTE Directive [2]").

The present document is part 9 of a multi-part deliverable covering the ElectroMagnetic Compatibility (EMC) standard for radio equipment and services, as identified below:

- Part 1: "Common technical requirements";
- Part 2: "Specific conditions for radio paging equipment";
- Part 3: "Specific conditions for Short-Range Devices (SRD) operating on frequencies between 9 kHz and 40 GHz";
- Part 4: "Specific conditions for fixed radio links and ancillary equipment and services";
- Part 5: "Specific conditions for Private land Mobile Radio (PMR) and ancillary equipment (speech and non-speech)";
- Part 6: "Specific conditions for Digital Enhanced Cordless Telecommunications (DECT) equipment";
- Part 7: "Specific conditions for mobile and portable radio and ancillary equipment of digital cellular radio telecommunications systems (GSM and DCS)";
- Part 8: "Specific conditions for GSM base stations";
- Part 9: "Specific conditions for wireless microphones and similar Radio Frequency (RF) audio link equipment, cordless audio and in-ear monitoring devices";**
- Part 10: "Specific conditions for First (CT1 and CT1+) and Second Generation Cordless Telephone (CT2) equipment";
- Part 11: "Specific conditions for analogue terrestrial sound broadcasting (Amplitude Modulation (AM) and Frequency Modulation (FM)) service transmitters";
- Part 12: "Specific conditions for Very Small Aperture Terminal, Satellite Interactive Earth Stations operated in the frequency ranges between 4 GHz and 30 GHz in the Fixed Satellite Service (FSS)";
- Part 13: "Specific conditions for Citizens' Band (CB) radio and ancillary equipment (speech and non-speech)";

- Part 14: "Specific conditions for analogue and digital terrestrial TV broadcasting service transmitters";
- Part 15: "Specific conditions for commercially available amateur radio equipment";
- Part 16: "Specific conditions for analogue cellular radio communications equipment, mobile and portable";
- Part 17: "Specific conditions for Wideband data and HIPERLAN equipment";
- Part 18: "Specific conditions for Terrestrial Trunked Radio (TETRA) equipment";
- Part 19: "Specific conditions for Receive Only Mobile Earth Stations (ROMES) operating in the 1,5 GHz band providing data communications";
- Part 20: "Specific conditions for Mobile Earth Stations (MES) used in the Mobile Satellite Services (MSS)";
- Part 22: "Specific conditions for ground based VHF aeronautical mobile and fixed radio equipment";
- Part 23: "Specific conditions for IMT-2000 CDMA Direct Spread (UTRA) Base Station (BS) radio, repeater and ancillary equipment";
- Part 24: "Specific conditions for IMT-2000 CDMA Direct Spread (UTRA) for Mobile and portable (UE) radio and ancillary equipment";
- Part 25: "Specific conditions for IMT-2000 CDMA Multi-carrier Mobile Stations and ancillary equipment";
- Part 26: "Specific conditions for IMT-2000 CDMA Multi-carrier Base Stations and ancillary equipment".

National transposition dates	
Date of adoption of this EN:	23 November 2001
Date of latest announcement of this EN (doa):	28 February 2002
Date of latest publication of new National Standard or endorsement of this EN (dop/e):	31 August 2002
Date of withdrawal of any conflicting National Standard (dow):	31 August 2003

1 Scope

The present document, together with EN 301 489-1 [1], covers the assessment of wireless microphones, similar RF audio link equipment, cordless audio and in-ear monitoring, intended for the transmission of music and speech, and associated ancillary equipment, in respect of ElectroMagnetic Compatibility (EMC).

Technical specifications related to the antenna port and emissions from the enclosure port of wireless microphones, similar RF audio link equipment, cordless audio and in-ear monitoring are not included in the present document. Such technical specifications are found in the relevant product standards for the effective use of the radio spectrum.

The present document specifies the applicable EMC tests, the test methods, the limits and the performance criteria for wireless microphones, similar RF audio link equipment, cordless audio, in-ear monitoring and associated ancillary equipment. This equipment can use analogue or digital modulation techniques.

Examples of equipment types covered by the present document are given in annex A.

Other types of transmitters or receivers, which are intended for combined use, with either wireless radio microphones, RF audio link equipment, cordless audio and in-ear monitoring shall be tested to their appropriate EMC standard.

Low quality speech applications as toy microphone, babyphones etc. operating at frequencies below 50 MHz, occupied bandwidth < 25 kHz and operating according CEPT ERC/REC 70-03, annex 1 [9] are excluded from the present document and have to be tested according to EN 301 489-3 [10].

In case of differences (for instance concerning special conditions, definitions, abbreviations) between the present document and EN 301 489-1 [1], the provisions of the present document take precedence.

The environmental classification and the emission and immunity requirements used in the present document are as stated in EN 301 489-1 [1], except for any special conditions included in the present document.

2 References

The following documents contain provisions which, through reference in this text, constitute provisions of the present document.

- References are either specific (identified by date of publication and/or edition number or version number) or non-specific.
- For a specific reference, subsequent revisions do not apply.
- For a non-specific reference, the latest version applies.

- [1] ETSI EN 301 489-1 (V1.3.1): "Electromagnetic compatibility and Radio spectrum Matters (ERM); ElectroMagnetic Compatibility (EMC) standard for radio equipment and services; Part 1: Common technical requirements".
- [2] Directive 1999/5/EC of the European Parliament and of the Council of 9 March 1999 on radio equipment and telecommunications terminal equipment and the mutual recognition of their conformity.
- [3] Directive 89/336/EEC of 3 May 1989 on the approximation of the laws of the Member States relating to electromagnetic compatibility.
- [4] Directive 98/34/EC of the European Parliament and of the Council of 22 June 1998 laying down a procedure for the provision of information in the field of technical standards and regulations.
- [5] ETSI EN 300 422-1: "Electromagnetic compatibility and Radio spectrum Matters (ERM); Wireless microphones in the 25 MHz to 3 GHz frequency range; Part 1: Technical characteristics and test methods".
- [6] ETSI EN 300 454-1: "Electromagnetic compatibility and Radio spectrum Matters (ERM); Wide band audio links; Part 1: Technical characteristics and test methods".

- [7] ETSI EN 301 357-1: "Electromagnetic compatibility and Radio spectrum Matters (ERM); Cordless audio devices in the range 25 MHz to 2 000 MHz; Consumer radio microphones and in-ear monitoring systems operating in the CEPT harmonized band 863 MHz to 865 MHz; Part 1: Technical characteristics and test methods".
- [8] ETSI EN 301 840-1: "Electromagnetic compatibility and Radio spectrum Matters (ERM); Digital radio microphones operating in the CEPT Harmonized band 1 785 MHz to 1 800 MHz; Part 1: Technical characteristics and methods of measurement".
- [9] CEPT ERC/REC 70-03: "Relating to the use of Short Range Devices (SRD)".
- [10] ETSI EN 301 489-3: "Electromagnetic compatibility and Radio spectrum Matters (ERM); ElectroMagnetic Compatibility (EMC) standard for radio equipment and services; Part 3: Specific conditions for Short-Range Devices (SRD) operating on frequencies between 9 kHz and 40 GHz".

3 Definitions and abbreviations

3.1 Definitions

For the purposes of the present document, the terms and definitions given in EN 301 489-1 [1] and the following apply:

companding: method of audio processing that compresses the audio dynamic range before transmission and then provides matching expansion of the signal in the receiver

NOTE: The method is used to improve the audio performance in the RF link.

integral antenna: antenna designed to be connected to the equipment without the use of a 50 Ω external connector and considered to be part of the equipment

NOTE: An integral antenna may be fitted internally or externally to the equipment.

switching range: maximum frequency range over which the receiver or transmitter can be operated without reprogramming or realignment

vehicle battery: battery used for the primary operation of the vehicle, i.e. the ignition or starting of the vehicle

3.2 Abbreviations

For the purpose of the present document, the following abbreviations apply:

EMC	ElectroMagnetic Compatibility
EUT	Equipment Under Test
RF	Radio Frequency
SINAD	ratio of (Signal + Noise + Distortion) to (Noise + Distortion)

4 Test conditions

For the purposes of the present document, the test conditions of EN 301 489-1 [1], clause 4 shall apply as appropriate. Further product related test conditions for wireless microphones, similar RF audio link equipment, cordless audio, in-ear monitoring equipment and ancillary equipment are specified in the present document.

4.1 General

For emission and immunity tests the test modulation, test arrangements, etc., as specified in the present document, clauses 4.1 to 4.5 shall apply.

For the purpose of EMC tests, body worn or hand held transmitters shall be mounted on a non-conductive stand at least 0,8 m from any conducting surface. The EUT and any other equipment required for the performance assessment before, during, and after the conclusion of the tests, shall be connected in a manner typical of normal intended use.

Whenever the EUT is provided with a detachable antenna, it shall be tested with the antenna fitted in a manner typical of normal intended use.

For immunity tests, if the equipment is of a category which permits it, a communications link shall be established at the start of the test and maintained during the test.

The test conditions shall be as follows:

- the transmitter shall be operated at its normal maximum RF output power modulated with a suitable modulation signal (see clause 4.5.1);
- for stand alone receivers or receivers of transceivers operating in simplex mode, the wanted RF input signal, coupled to the receiver, shall be modulated with a suitable modulation signal (see clause 4.5.2);
- for duplex transceivers, the wanted RF input signal, coupled to the receiver, shall be modulated with a suitable modulation signal (see clause 4.5.2). The transmitter shall be operated at its normal maximum output power, modulated with the test modulation signal, coupled to the transmitter from the output of the receiver (repeater mode);
- Digitally modulated systems shall use a defined interface to convert between analogue and digital domain (and vice versa).

4.2 Arrangements for test signals

The provisions of EN 301 489-1 [1], clause 4.2 shall apply.

4.2.1 Arrangements for test signals at the input of transmitters

The provisions of EN 301 489-1 [1], clause 4.2.1 shall apply with the following modifications.

For transmitters designed to operate from an integral or dedicated microphone (see figure 2) it shall be permissible to use an acoustic coupling device to inject the normal test modulation signal (see figure 3). The acoustic coupling device may be provided by the manufacturer.

For equipment which can use a variety of audio capsules, the manufacturer shall declare the type of capsule, e.g. dynamic, electret, or condenser, to be provided with the system. Only one type of capsule shall be tested. All other capsules shall be deemed as compliant. The transmitter shall be tested at its most sensitive input with the test capsule.

For equipment not designed to use an integral or dedicated microphone, the test signal shall be fed in electrical form to the most sensitive input socket (see figure 1) using maximum length cables as normally supplied by the manufacturer with the equipment.

The modulation signal used for the tests shall be a 1 kHz sine wave tone at a level declared by the manufacturer to obtain 100 % audio modulation.

The manufacturer may provide a suitable companion receiver that can be used to set up a communications link. In this case a suitable attenuator in the companion receiver input may be necessary, see annex B for further details.

In the case of systems with a digital audio input and outputs this test signal has to be presented via a suitable test fixture converting the analogue signal to the digital domain and vice-versa. The applicant shall provide details on the interface and test fixture used for the test.

4.2.2 Arrangements for test signals at the output of transmitters

The provisions of EN 301 489-1 [1], clause 4.2.2 shall apply.

4.2.3 Arrangements for test signals at the input of receivers

The provisions of EN 301 489-1 [1], clause 4.2.3 shall apply with the following modifications.

The wanted RF input signal to the receiver should be modulated with a suitable signal corresponding to 100 % audio modulation (maximum channel loading). If it is not appropriate to provide a modulated RF signal to the receiver, the test may be performed using an unmodulated wanted RF input signal.

The level and make up of the wanted RF input signal shall be declared by the manufacturer. The level chosen shall be set to a value 60 dB above the threshold sensitivity of the receiver. Other systems than analogue radio microphones can define another level more in line with the application. The level used shall be recorded in the test report.

The manufacturer may provide a suitable companion transmitter that can be used to set up a communications link. In this case a suitable attenuator in the EUT input may be necessary.

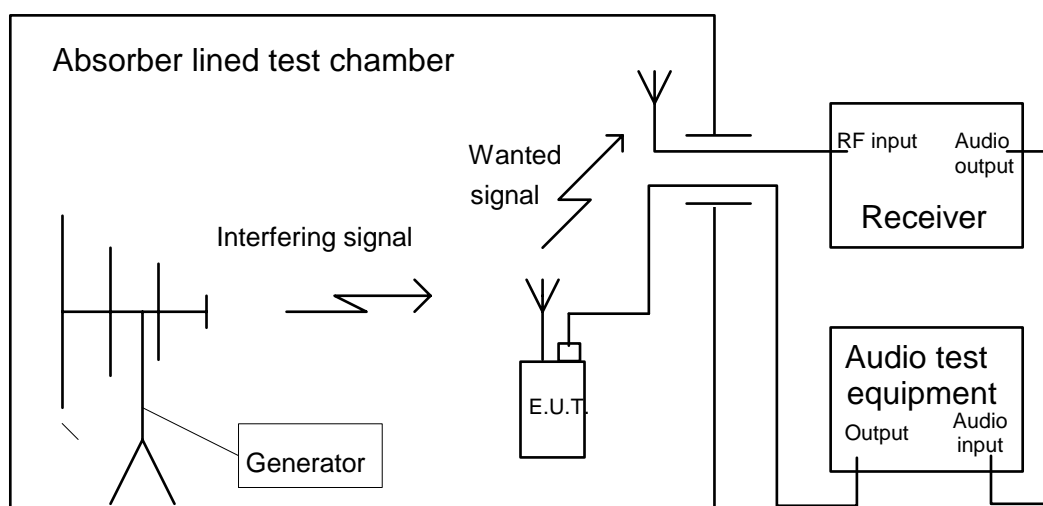

Figure 1: Test configuration for integral antenna; transmitter operation - electrical input

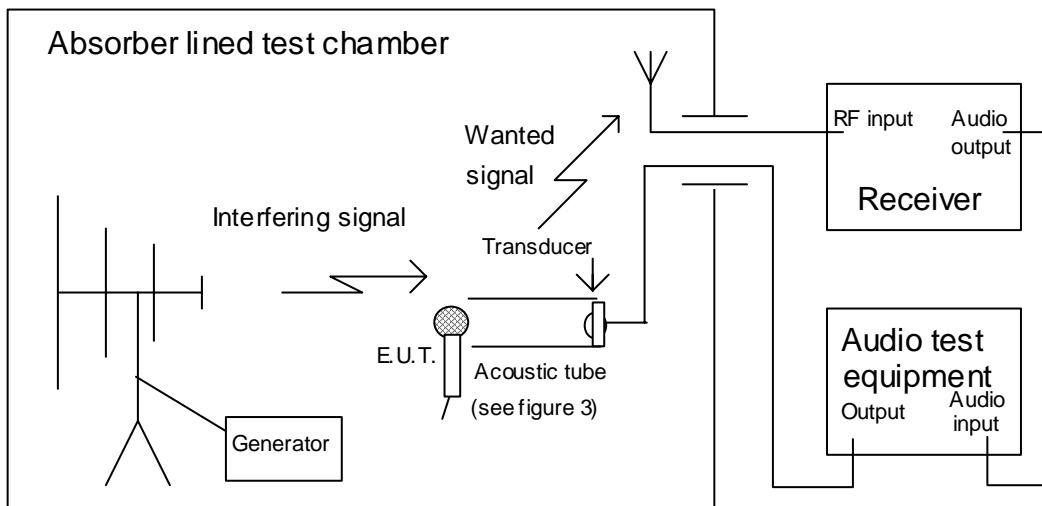

Figure 2: Test configuration for integral antenna; transmitter operation - acoustic input

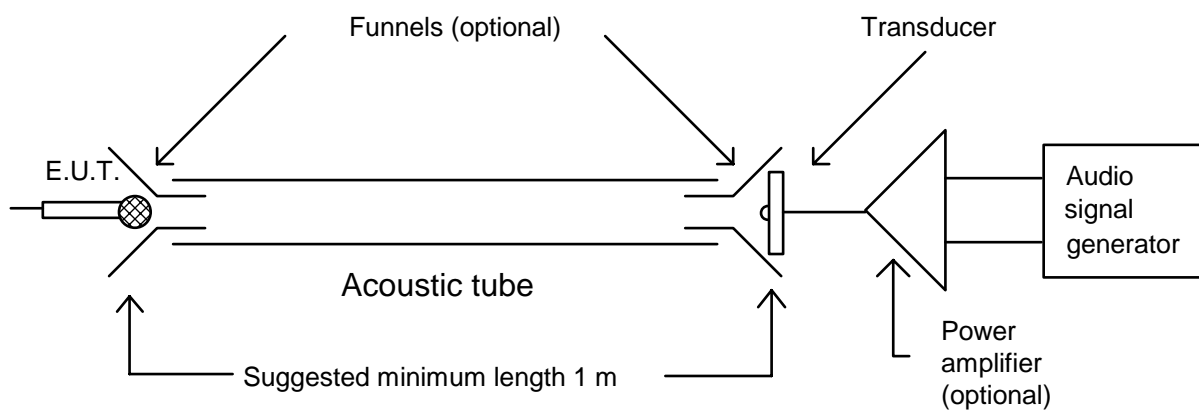
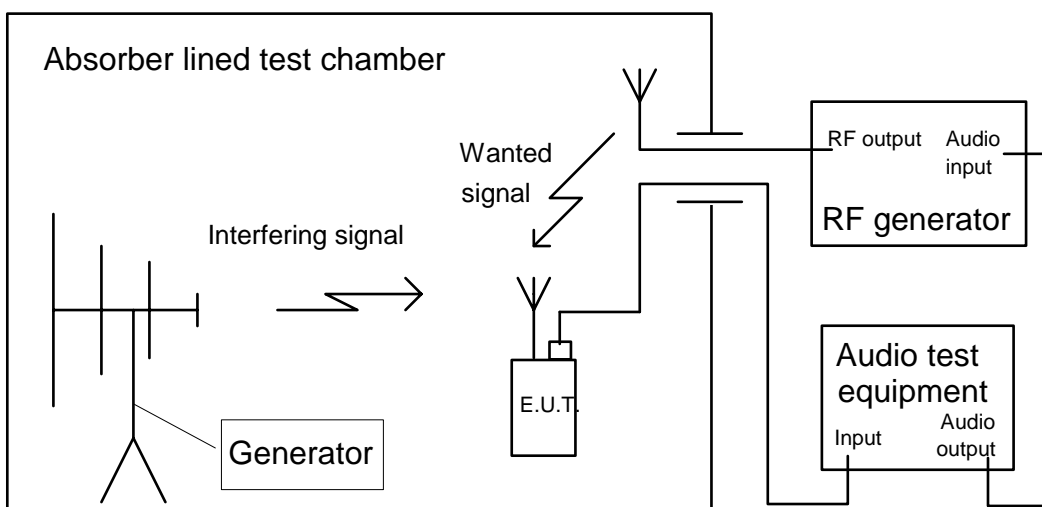

Figure 3: Example of acoustic coupling jig



NOTE: The RF generator may be a companion transmitter sited inside the test chamber if necessary.

Figure 4: Test configuration for integral antenna; receiver operation

4.2.4 Arrangements for test signals at the output of receivers

The provisions of part 1 EN 301 489-1 [1], clause 4.2.4 shall apply with the following modification.

The audio frequency output of the equipment shall be suitably coupled to the SINAD measuring system outside of the test environment. The characteristics of the SINAD measuring system shall be such that the upper -3 dB frequency of its detector part is to exceed 16 kHz, and its electrical measurement flatness error between 40 Hz and 16 kHz is not to exceed ± 2 dB. The coupling means actually used shall be recorded in the test report.

In the case of systems with a digital audio output a suitable test fixture to convert from digital to analogue signals shall be defined by the applicant. The applicant shall provide details on the interface and test fixture used for the test. The interface must be capable to reach the specifications from above clause.

4.2.5 Arrangements for testing transmitter and receiver together (as a system)

The provisions of EN 301 489-1 [1], clause 4.2.5 shall apply.

In case of digitally modulated systems, the applicant shall define suitable test fixtures for converting from the analogue to the digital domain and vice versa. This definition shall be included in the test report.

4.3 Exclusion bands

The provisions of EN 301 489-1 [1], clause 4.3 shall apply.

4.3.1 Receiver and receivers of transceivers exclusion band

The exclusion band for receivers and receivers of transceivers is the frequency range determined by the switching range, as declared by the manufacturer, extended as follows:

- 1) Category 1 and 2 equipment (as defined in clause 6):
 - the lower frequency of the exclusion band is the lower frequency of the switching range, minus 5 % of the centre frequency of the switching range;
 - the upper frequency of the exclusion band is the upper frequency of the switching range, plus 5 % of the centre frequency of the switching range.
- 2) Category 3 equipment (as defined in clause 6):
 - the lower frequency of the exclusion band is the lower frequency of the switching range, minus 5 % of the centre frequency of the switching range, or minus 10 MHz, whichever will result in the lowest frequency;
 - the upper frequency of the exclusion band is the upper frequency of the switching range, plus 5 % of the centre frequency of the switching range, or plus 10 MHz, whichever will result in the highest frequency.

The manufacturer shall state the category of equipment on the documentation accompanying the product, and shall declare the category to the test house in the form of a manufacturer's declaration.

4.3.2 Transmitter exclusion band

The lower frequency of the exclusion band is the lower frequency of the switching range, minus 5 % of the centre frequency of the switching range.

The upper frequency of the exclusion band is the upper frequency of the switching range, plus 5 % of the centre frequency of the switching range.

4.4 Narrow band responses of receivers

The provision of EN 301 489-1 [1], clause 4.4 shall apply.

The identification criterion for narrow band responses of the EUT is a reduction of the observed SINAD level of the audio output below the relevant category limit set out in table 2, see clause 6.2.

The nominal frequency offset used for the identification of narrowband responses shall be twice the bandwidth of the receiver IF filter immediately preceding the demodulator, as declared by the manufacturer, for the first part of the identification procedure, and two and one half times the bandwidth of the receiver for its second part.

For digital systems the narrowband response shall be limited to less than 3 times the declared bandwidth (B) of the system. See [5], [6], [7], [8].

4.5 Normal test modulation

4.5.1 Transmitters

The transmitter shall be modulated with a sinusoidal audio frequency signal of 1 000 Hz, provided either by a suitable acoustic coupling means or by a shielded transmission line (e.g. a coaxial cable). The level of this audio signal shall be adjusted corresponding to 100 % audio modulation (maximum channel loading) of the wanted RF carrier.

For digitally modulated systems the applicant shall specify the modulation method and its parameters and provide a suitable test fixture to allow for testing similar to 100 % audio modulation level.

4.5.2 Receivers

The receivers wanted RF input signal shall be set to the operation frequency of the receiver within the designated operation frequency band and modulated with a sinusoidal audio frequency of 1 000 Hz, provided either by a test antenna located within the test environment (integral antenna receivers) or a shielded transmission line such as a coaxial cable (non-integral antenna receivers). The level of the modulation signal shall be adjusted resulting in 100 % audio modulation (maximum channel loading) of the receivers wanted RF input signal.

For digitally modulated systems the applicant shall specify the modulation method and its parameters and provide a suitable test fixture to allow for testing similar to 100 % audio modulation level.

5 Performance assessment

5.1 General

The provision of EN 301 489-1 [1], clause 5.1 shall apply with the following modification.

In addition, the manufacturer shall at the time of submission of the equipment for test, supply the following information to be recorded in the test report:

- the applicable equipment category (category 1, 2 or 3) according to clause 6;
- the coupling means to be used for the application of the modulation signal to the EUT and for monitoring the output of the EUT; and
- the level and make up of the RF test signal for the establishment of the communications link;
- description of test fixtures, e.g. for converting from the analogue to the digital domain or vice versa.

5.2 Equipment which can provide a continuous communications link

The provision of EN 301 489-1 [1], clause 5.2 shall apply.

5.3 Equipment which does not provide a continuous communications link

The provision of EN 301 489-1 [1], clause 5.3 shall apply.

5.4 Ancillary equipment

The provision of EN 301 489-1 [1], clause 5.4 shall apply.

5.5 Equipment classification

The provision of EN 301 489-1 [1], clause 5.5 shall apply.

6 Performance criteria

The product family of wireless microphones, similar RF audio link equipment, cordless audio, in-ear monitoring and associated ancillary equipment is divided into three categories of equipment, each having its own set of performance criteria.

- **Category 1 equipment** comprises wireless microphones, similar RF audio link equipment, and associated ancillary equipment intended for **professional applications**.
- **Category 2 equipment** comprises consumer wireless microphones, cordless audio devices, in-ear monitoring devices and associated ancillary equipment intended for **domestic entertainment**.
- **Category 3 equipment** comprises consumer wireless microphones, cordless audio, wireless headphones and associated ancillary equipment intended for **general consumer purposes**.
- The information required to enable use in accordance with the intended purpose of the product, declared as "professional applications" (Category 1), "domestic entertainment" (Category 2), or "general consumer" (Category 3), shall be contained in the accompanying user product documentation or.

The establishment of the communication link at the start of the test, its maintenance and the assessment of the recovered signal (e.g. audio output) are used as the performance criteria for the evaluation of the essential functions of the equipment during and after the test.

The performance criteria A, B, and C set out in table 1 shall be used in the following manner:

- performance criteria A for immunity tests with phenomena of a continuous nature;
- performance criteria B for immunity tests with phenomena of a transient nature;
- performance criteria C for immunity tests with power interruptions and voltage dips exceeding a certain period of time.

6.1 General performance criteria

The equipment shall meet the performance criteria specified in table 1, as detailed in the special performance criteria in clause 6.2, 6.3, or 6.4, as appropriate.

Table 1: General performance criteria

During test	After test	Criteria
Operate as intended; Degradation of performance (see note 1); No loss of function.	Operate as intended; No degradation of performance (see note 2); No loss of function.	A
Loss of function (one or more).	Operate as intended; No degradation of performance (see note 2); Functions self-recoverable.	B
Loss of function (one or more).	Operate as intended; No degradation of performance (see note 2); Functions recoverable by the operator.	C
<p>NOTE 1: Degradation of performance during the test is understood as a degradation to a level not below a minimum performance level specified by the manufacturer for the use of the apparatus as intended. In some cases the specified minimum performance level may be replaced by a permissible degradation of performance. If the permissible degradation of performance is not specified by the manufacturer, then this may be derived from the product description and documentation (including leaflets and advertising) and what the user may reasonably expect from the apparatus if used as intended.</p> <p>NOTE 2: No degradation of performance after the test is understood as no degradation below a minimum performance level specified by the manufacturer for the use of the apparatus as intended. In some cases the specified minimum performance level may be replaced by a permissible degradation of performance. After the test no change of actual operating data or user retrievable data is allowed. If the minimum performance level or the permissible degradation of performance is not specified by the manufacturer, then either of these may be derived from the product description and documentation (including leaflets and advertising) and what the user may reasonably expect from the apparatus if used as intended.</p>		

6.2 Performance criteria for equipment which provides a continuous communication link

The establishment of the communications link at the start of the test, the maintenance of the communications link and the assessment of the recovered signal information, e.g. an audio signal, shall be used as the performance criteria to ensure that the essential functions of the transmitter and/or receiver are evaluated during and after the test.

The equipment shall meet the minimum performance criteria as specified for the appropriate category of equipment in clauses 6.2.1 and 6.2.2.

6.2.1 Performance criteria for Continuous phenomena applied to Transmitters (CT) and Receivers (CR)

The following performance criteria for continuous phenomena apply for transmitters (CT) and receivers or receiver parts of simplex or duplex transceivers (CR) permitting the establishment of a continuous communications link:

- before the test it shall be verified that the EUT, when coupled through the test equipment and not subjected to EMC stress is capable of producing a SINAD figure of at least 3 dB above the category limit specified in table 2;
- during each individual exposure in the test sequence it shall be verified, by appropriate means supplied by the manufacturer, that the communications link is maintained;
- at the conclusion of the test the EUT shall operate as intended with no loss of user control functions or stored data, as declared by the manufacturer, and the communications link shall have been maintained during the test.

During and after the tests the audio output shall be monitored and assessed. During the test, the SINAD of the audio output shall not result in levels below the relevant category limit specified in table 2. After the test, the SINAD shall recover to that level recorded before the test or at least to levels not below the relevant category limit specified in table 2.

Table 2: Continuous phenomena, minimum performance criteria

Equipment category	Minimum performance criterion	Intended use
Category 1	30 dB SINAD	Professional applications
Category 2	20 dB SINAD	Domestic entertainment
Category 3	6 dB SINAD	General consumer

Where the EUT is a transmitter only, and a stand-by mode of operation is provided, the tests shall be repeated with the EUT in stand-by mode of operation to ensure that unintentional transmission does not occur.

Where the EUT is a transceiver, under no circumstances shall the transmitter operate unintentionally during the test.

6.2.2 Performance criteria for Transient phenomena applied to Transmitters (TT) and Receivers (TR)

The following performance criteria for transient phenomena apply for transmitters (TT) and receivers or receiver parts of simplex or duplex transceivers (TR) permitting the establishment of a continuous communications link:

- before the test it shall be verified that the EUT, when coupled through the test equipment and not subjected to EMC stress is capable of producing a SINAD figure of at least 3 dB above the category limit specified in table 2.
- at the conclusion of each exposure in the test sequence the EUT shall operate with no user noticeable loss of the communications link;
- at the conclusion of the total test comprising of a series of individual exposures the EUT shall operate as intended with no loss of user control functions or stored data, as declared by the manufacturer, and the communications link shall have been maintained during the test.

After the tests the audio output shall be monitored and assessed. After the test the SINAD shall recover to that level recorded before the test or at least to levels not below the relevant category limit specified in table 2.

Where the EUT is a transmitter only, and a stand-by mode of operation is provided, the tests shall be repeated with the EUT in stand-by mode of operation to ensure that unintentional transmission does not occur.

Where the EUT is a transceiver, under no circumstances shall the transmitter operate unintentionally during the test.

6.3 Performance criteria for equipment which does not provide a continuous communication link

The provisions of EN 301 489-1 [1], clause 6.3 shall apply with the following modifications.

For immunity tests with continuous phenomena, equipment not permitting the establishment of a continuous communications link and ancillary equipment intended to be tested on a stand alone basis shall meet the following performance criteria:

- performance criteria A for category 1 equipment;
- performance criteria C for categories 2 and 3 equipment;

as specified in table 1.

For immunity tests with transient phenomena, equipment not permitting the establishment of a continuous communications link and ancillary equipment intended to be tested on a stand alone basis shall meet the performance criteria B as given in table 1, except for immunity tests with voltage dips and interruptions (see EN 301 489-1 [1], clause 9.7), where it is explicitly stated that the communications link need not be maintained in which case performance criteria C from table 1 shall apply.

6.4 Performance criteria for ancillary equipment tested on a stand alone basis

The provision of EN 301 489-1 [1], clause 6.4 shall apply.

7 Applicability overview

7.1 Emission

7.1.1 General

EN 301 489-1 [1], table 2, contains the applicability of EMC emission measurements to the relevant ports of radio and/or associated ancillary equipment.

7.1.2 Special conditions

The following special conditions set out in table 3, relate to the emission test methods used in EN 301 489-1 [1], clause 8.

Table 3: Special conditions for EMC emission measurements

Reference to clauses in EN 301 489-1 [1]	Special product-related conditions, additional to or modifying the test conditions in EN 301 489-1 [1], clause 8
8.1 Test configuration; Methods of measurement and limits for EMC emissions	The radio equipment shall be operated on one channel frequency, which is close to the middle of the switching range declared by the manufacturer. In transmit mode of operation, the transmitter shall be operated to obtain its maximum rated RF power.
8.3.2 Test method; DC power input/output ports	The measurement frequency range extends from 150 kHz to 30 MHz, excluding the transmitter exclusion band in transmit mode of operation. The limits for conducted emissions apply for all modes of operation of the EUT.
8.4.2 Test method; AC mains power input/output ports	The measurement frequency range extends from 150 kHz to 30 MHz, excluding the transmitter exclusion band in transmit mode of operation. The limits for conducted emissions apply for all modes of operation of the EUT.

7.2 Immunity

7.2.1 General

EN 301 489-1 [1], table 3, contains the applicability of EMC immunity measurements to the relevant ports of radio and/or associated ancillary equipment.

7.2.2 Special conditions

The following special conditions set out in table 4, relate to the immunity test methods and performance criteria used in EN 301 489-1 [1], clause 9.

Table 4: Special conditions for EMC immunity tests

Reference to clauses in EN 301 489-1 [1]	Special product-related conditions, additional to or modifying the test conditions in EN 301 489-1 [1], clause 9
9.1 Test configuration; Test methods and levels for immunity tests	For immunity tests of transmitters, the transmitter shall be operated at its maximum rated RF output power. The immunity tests shall be performed with the EUT successively set to all modes of operation available for the EUT.

Annex A (informative): Examples of wireless microphones, cordless audio, in-ear monitoring and similar RF audio link equipment within the scope of the present document

A.1 Wireless radio microphone equipment

Wireless radio microphone equipment operates with a continuous RF output signal and normally is in continuous operation for a number of hours. The modulation can be analogue [5] or digital [8]. The transmitter typically operates at a maximum RF output power of 50 mW [5]. Wireless radio microphones are intended for professional use at theatres, shows, broadcast etc. and may be distinguished from other voice or speech communication equipment (e.g. PMR) by the following operational characteristics:

- wider audio bandwidth;
- higher audio signal to noise ratio;
- lower audio frequency distortion.

Aids for the handicapped, tour guides systems, in-ear monitoring and similar constant RF devices operate in a similar manner to wireless microphones, but with variations of bandwidth and a reduced RF output power and possibly reduced quality of speech or voice signal transmission.

Consumer microphones are intended for domestic and consumer use in the band 863 MHz to 865 MHz. They are intended for unlicensed operation at 10 mW ERP. The present document applies to consumer microphones and in-ear monitoring equipment as defined in EN 301 357-1 [7]: Cordless audio devices in the range 25 MHz to 2 000 MHz, Consumer radio microphones and in ear monitoring systems in the CEPT harmonized band 863 MHz to 865 MHz.

Digital radiomicrophones are intended for professional applications such as theatres, onstage, broadcast etc. in the band 1 785 MHz to 1 800 MHz. The present document applies to digital radiomicrophones as defined in EN 301 840-1 [8]: digital wireless microphones in the 1 785 MHz to 1 800 MHz frequency range.

A.2 Cordless audio equipment

Cordless audio equipment encompasses radio linked headphones and loudspeakers. The transmitters may be installed in a building, fitted in a vehicle or body worn. The term cordless is also used to describe infra red and other non-RF "wireless" links, but in the context of the present document it is restricted to RF operating systems only. Stereo analogue or digital equipment can be designed for required channel bandwidths of 300 kHz however multichannel equipment for e.g. surround sound systems may need higher bandwidths 600 kHz or 1 200 kHz as described in EN 301 357-1 [7].

In this class of operation, following applications can be identified (non-exhaustive list) [7]:

- **cordless loudspeakers:** Cordless loudspeakers are used in a domestic or consumer environment and are used to allow wireless operation from audio or TV systems and alike.
- **wireless headphones:** Wireless headphones are used in a domestic or consumer environment to allow wireless operation for audio and TV and alike.
- **in-ear monitoring:** In-ear monitoring equipment is used by stage and studio performers to receive personal fold back (monitoring) of the performance. This can be just their own voice or a complex mix of sources. This equipment is usually stereo or 2 channel audio.
- **personal cordless:** Personal cordless transmitters are to enable the body worn personal stereo equipment to be wire free.

- **in-vehicle cordless:** In vehicle systems are used for private listening in automobiles and other methods of transport (where permitted).
- **broadband multichannel applications:** Broadband multichannel systems are used for the transmission of high quality digital audio. These can e.g. surround sound systems or low/uncompressed audio. They are intended to be used in spectrum above 1 GHz and use bandwidths of typically 600 kHz or 1 200 kHz.

A.3 RF audio link equipment covered within the scope of the present document

Wireless audio links are intended for professional use and operate at high RF power levels to bridge more operating range distance in outdoor use. They are used in spectrum identified by the National administration (licensed). The present document applies to RF audio link equipment as defined in EN 300 454-1 [6] operating in the 25 MHz to 3 GHz frequency range, and associated ancillary equipment.

Annex B (normative): Acoustic stimulation of wireless radio microphones and similar radio communications link equipment, conditions for the test set up and configuration

B.1 General

This annex defines the methods of stimulating the EUT when carrying out the necessary EMC tests specified in the present document, in recognition of the rather unusual nature of radio microphones, as compared with the generality of radio products.

Radio microphones vary enormously in their sensitivity and acoustic directivity of their microphones.

In testing wireless radio microphones, it should be borne in mind that many products employ companding techniques.

In the event of difficulty, or uncertainty about the characteristics of the sample submitted for the EMC conformity testing, discussion with the manufacturer is encouraged.

B.2 Audio excitation

As part of the EMC test sequence specified in the present document it is necessary to provide an audio excitation signal to the microphone transducer. This may be achieved in at least two ways, as follows:

- 1) by means of an electro-acoustic resonator (in order to avoid distortion of the calibrated field, this shall be placed outside the physical area of calibration, and be non-metallic); or
- 2) by means of an acoustic tube (this may be rigid or flexible, but shall have an acoustically "hard" wall, be of non-conducting material, and be of constant inner diameter throughout its length).

The driver transducer shall be large enough, and excited strongly enough, to be able to deliver sufficient sound pressure at the microphone to fully excite the EUT's modulator. Overdrive shall however be avoided.

The driver transducer shall be placed well away from the EUT's microphone, (because it will ordinarily be a moving coil magnetic type), in order to avoid inter-transducer magnetic coupling, and in order to avoid distortion of the electromagnetic test field.

Coupling to the driver transducer, and to the EUT's microphone transducer, may be by means of funnels or other appropriate means. The attachments shall be fixed and firm throughout the test sequence.

When the transducer is coupled to the EUT by means of an acoustic tube, bends in the tube shall be avoided or minimized. Any bends in the tube shall always have a radius that is large in relation to the inner diameter of the tube. Standing waves in the tube may be overcome by lightly packed cotton wool damping pads placed at 150 mm intervals along the length of the tube. It is recommended that the driver transducer is located inside the test chamber, thus minimizing the length of the tube.

NOTE: In trials of this test method a tube length of 1m has been successfully used. The tube was 12,5 mm bore plastic reinforced water hose. The driver transducer was a 75 mm car radio speaker, with a large ferrite magnet, capable of cone movement exceeding 10 mm peak-to-peak. The driver was coupled into the pipe by means of a domestic plastic funnel.

History

Document history		
V1.1.1	September 2000	Publication
V1.2.1	July 2001	One-step Approval Procedure OAP 20011123: 2001-07-25 to 2001-11-23
V1.2.1	November 2001	Publication